

Raychem NGC-UIT-ORD

USER INTERFACE TERMINAL FOR RAYCHEM NGC SYSTEMS INSTALLATION INSTRUCTIONS

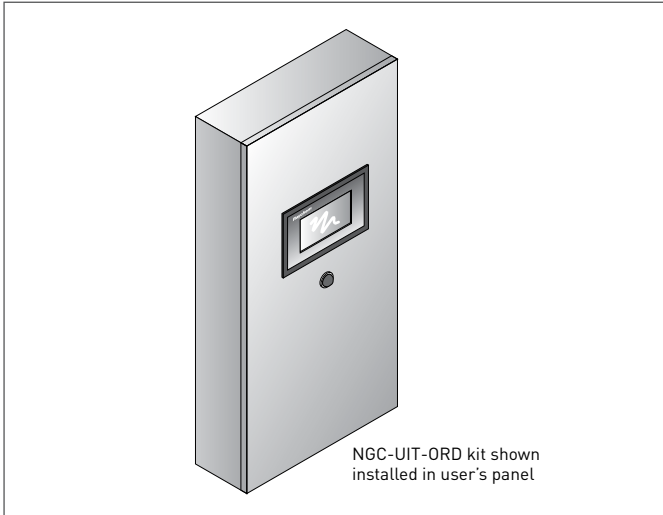

DESCRIPTION

The NGC-UIT-ORD is a panel mounted display used in conjunction with other approved Raychem control and monitoring devices. The NGC-UIT-ORD is rated NEMA 12, and the display can best be viewed indoors. The NGC-UIT-ORD kit includes all hardware required for mounting in a suitable electrical panel. These instructions describe how to mount the NGC-UIT-ORD in an electrical panel and are intended only for personnel experienced in panel construction.

TOOLS REQUIRED

- Masking tape
- #16 (3/16) drill bit
- 11/32 inch nut driver
- Metal file
- Jig saw (recommend using carbon steel blade with 24 TPI)

APPROVALS/CERTIFICATIONS

Nonhazardous Locations



General

Supply voltage	100 – 240 Vac $\pm 10\%$, .25 A max/25 VA, 50/60 Hz
Operating temperature	-40°F to 149°F (-40°C to 65°C)
EMC	Immunity – Industrial Emission – Commercial / Light Industrial
Vibration	Unit tested to IEC-60068-2-6
Shock	Unit tested to IEC-60068-2-27
Dimensions	10 1/4 in wide X 6 5/8 in high X 3 in deep (260 mm wide X 168 mm high X 76 mm deep)

Control Outputs

Relay outputs	Three relay outputs, Form C contacts, switching loads up to 277 Vac/3 Amps Relays may be assigned for alarm outputs 11 position Phoenix-style pluggable screw terminal connector with retaining screws
---------------	--

Status LEDs

Relay	Three LEDs showing the ON/OFF Status for each relay, LED ON indicates relay is energized
Field	Transmit and Receive activity
Local/Remote	Transmit and Receive activity
USB host	Three colors showing status: Red = USB key fault Green = USB key inserted Yellow = USB in use
UIT status	Three colors showing system status: Green = Normal Condition Red = Fault Condition Yellow = loading software/configuration

Network Connection

Local port/ remote	RS-485/RS-232, selectable. Port may be used to communicate with Supervisor Software RS-232 is non-isolated, RJ-11 connection RS-485, 2-wire Isolated. Phoenix-style pluggable screw terminal connector with retaining screws. Maximum number of devices 256. Fail safe design with optional termination resistors Data Rate: 2400 to 57600 baud Maximum cable length for RS-485 not to exceed 4000 feet (1200 m). Cable to be shielded twisted pair
Field port	RS-485 2-wire isolated. Used to communicate with external devices, such as NGC-30-CRM, 5GF-C and RMM2. Maximum cable length not to exceed 4000 ft (1200 m). Cable to be shielded twisted pair Phoenix style pluggable screw terminal connector with retaining screws. Maximum number of devices 256. Fail safe design with optional termination resistors Data rate to 9600 baud
LAN	10/100 Base-T Ethernet port with Link and Activity Status LEDs
USB port	USB 2.0 Host port Type A receptacle
LCD Display	
Display	LCD is a 6.5 inch QVGA, color TFT transreflective device with integral CCFL backlight.
Touch screen	4-wire resistive touch screen interface for user entry. Usable with gloved fingers

WARNING:

This component is an electrical device which must be installed correctly to ensure proper operation and to prevent shock or

fire. Read these important warnings and carefully follow all the installation instructions.

- Component approvals and performance are based on the use of specified parts only. Do not use substitute parts.

KIT CONTENTS

Item	Qty	Description
A	1	NGC-UIT-ORD display
B	1	Sealing gasket
C	10	#8 washers (stainless steel)
D	10	#8/32 locknuts (stainless steel)
E	1	5 ft. (1.5 m) RS-232 adaptor cable

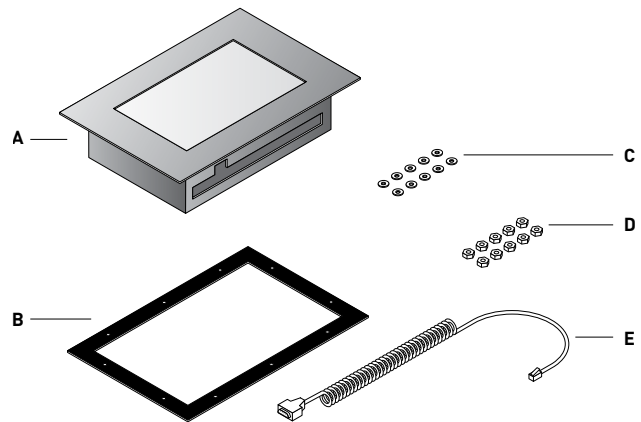

OVERVIEW OF INSTALLATION PROCEDURE FOR NGC-UIT-ORD

Page #		
A.	Provide suitable panel enclosure, and determine locations for NGC-UIT-ORD assembly in panel	2
B.	Cut opening and mount NGC-UIT-ORD on front of panel	3
C.	Installing common alarm light	4
D.	Connect power and communication to the UIT	4
E.	Servicing	5
F.	Cleaning	5
G.	Configuration switches	5
H.	Reset switch	5
I.	Cutting template	7

A. PROVIDE SUITABLE PANEL ENCLOSURE, AND DETERMINE LOCATIONS FOR NGC-UIT-ORD ASSEMBLY IN PANEL

1. Provide suitable panel enclosure

To protect its electronic components, the NGC-UIT-ORD must be mounted in a minimum NEMA 1 enclosure. A NEMA 12 or better enclosure is recommended. The NGC-UIT-ORD assembly comes with a sealing gasket and hardware to mount the enclosure.

Note: The Raychem NGC-UIT-ORD is designed for operation in ambient temperatures from -40°F to 149°F (-40°C to 65°C). If the ambient temperature is outside this range, a space heater and/or cooling fan will be required in the panel.

2. Determine locations for the NGC-UIT-ORD assembly in the electrical panel

The NGC-UIT-ORD should be located on the front of the panel near eye level (for convenient viewing). The NGC-UIT-ORD assembly is an electronic unit and must not be located where it will be exposed to strong magnetic fields or excessive vibration.

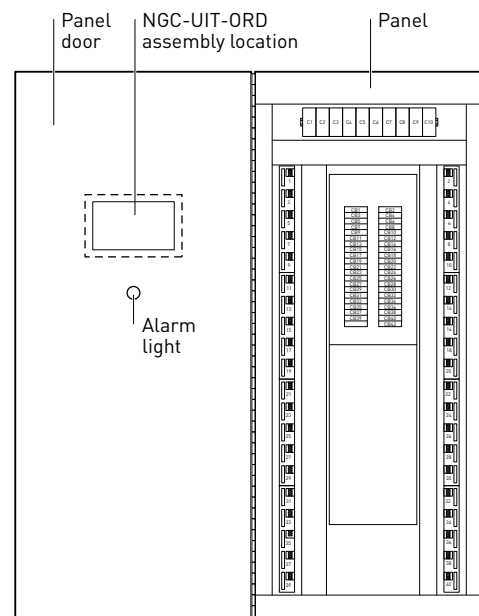

B. CUT OPENING AND MOUNT NGC-UIT-ORD ON FRONT OF PANEL

1. Locate the NGC-UIT-ORD on front of panel

Locate the NGC-UIT-ORD assembly on the front of the panel at a level convenient for viewing. Make sure the cover on the back of the assembly will not interfere with existing panel hardware. (Refer to full size cut-out template with all dimensions on page 7.)

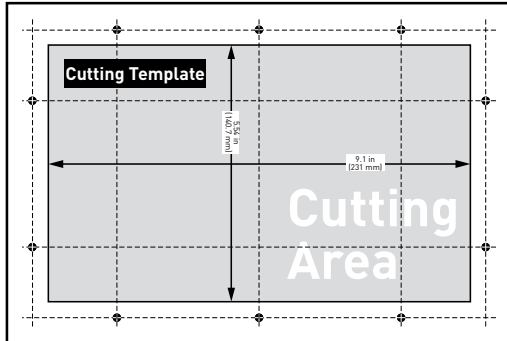

Note: Cutting the opening for the display is a craft sensitive procedure; if it is not done correctly, the panel door can be damaged. The procedure for laying out and cutting the opening for the display must be undertaken with care, and by personnel qualified and experienced in panel construction.

2. Prepare and mark the position of the display opening and mounting holes

- Use the cut-out template on page 7 to lay out the opening for the NGC-UIT-ORD display.
- Apply two layers of masking tape around the outer perimeter of the intended opening to prevent scratching the panel surface with the jigsaw.
- Use the template on page 7 to mark the opening and the mounting holes for the user interface assembly.

3. Cut the display opening

Cut the opening for the NGC-UIT-ORD with a jigsaw using a 24 TPI blade. Take care not to damage the panel door. Remove all rough edges and burrs with a metal file before proceeding.

4. Drill the mounting holes

Drill the 10 holes with a #16 (3/16 in) drill bit to mount the NGC-UIT-ORD assembly in the panel.

Note: The following steps are most easily accomplished if the panel door is on a horizontal surface.

5. Position the gasket on the outside of the panel door

- Place the sealing gasket between the NGC-UIT-ORD and front side of enclosure door.

6. Mount the user interface assembly onto the panel door

- Place the NGC-UIT-ORD assembly in position; the ten mounting screws go through the ten holes on the NGC-UIT-ORD assembly mounting plate (see figure below).

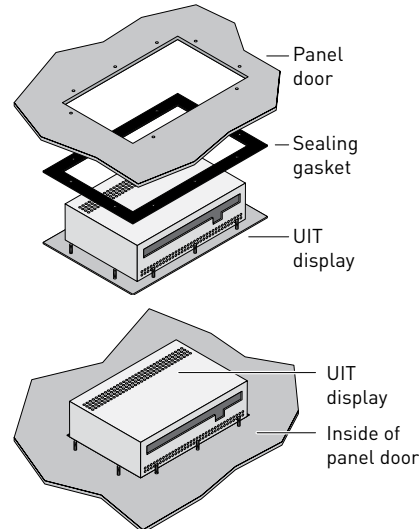

- Place a #8 washer and #8/32 locknut on each of the ten mounting studs; fasten only hand tight.

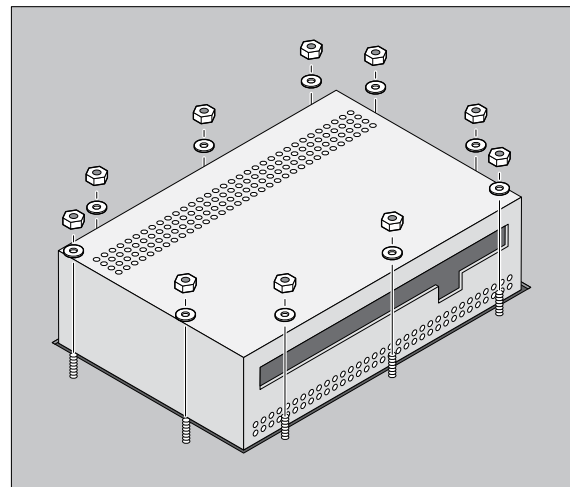

- Look at the front of the panel, and align the NGC-UIT-ORD assembly so it is level (loosen nuts if necessary to reposition the NGC-UIT-ORD assembly).
- After the display and gasket are properly positioned, tighten the nuts to 10 inch pounds of torque using an 11/32 inch nut driver.

Do not overtighten and risk damage to hardware.

C. INSTALLING COMMON ALARM LIGHT

An alarm light must be installed on the front of the enclosure to indicate when an alarm has occurred. Relay 1 has already been programmed for this purpose, and must be connected as shown.

If desired, install a push-to-test alarm light and/or interposing relay and test button.

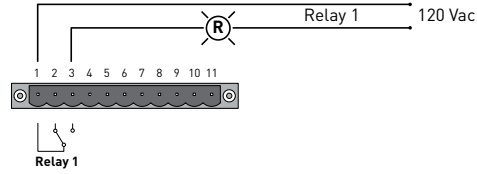

D. CONNECT POWER AND COMMUNICATION TO THE UIT

Power and Earth Ground

1. Connect 100 to 240 Vac $\pm 10\%$ to AC input terminals (Line/L1 and Neutral/L2). Maximum wire size is 12 AWG, minimum wire size is 18 AWG.

Ensure that branch circuit breaker does not exceed 15A and is installed in accordance with local electrical codes.

2. A ground conductor must be terminated at the ground terminal of the AC Input connector.

Communication

Field side port

1. This port is used to communicate with ModBus[®] devices. Connections to these terminals should be a shielded, twisted pair cable. (Belden CDT cable 8761 or equivalent, maximum length is 4,000 ft [1.2 km]). For more information, refer to the NGC-30 Programming Guide (H58186) and the NGC-30 Installation Manual (H57878).

Local port

1. This port is used to communicate to a host computer and is user selectable for either RS-232, RS-485 or Ethernet.
2. If the RS-232 port is utilized, the supplied RJ-11 to RS-232 adaptor cable must be used. For more information, refer to the NGC-30 Programming Guide (H58186) and the NGC-30 Installation Manual (H57878).

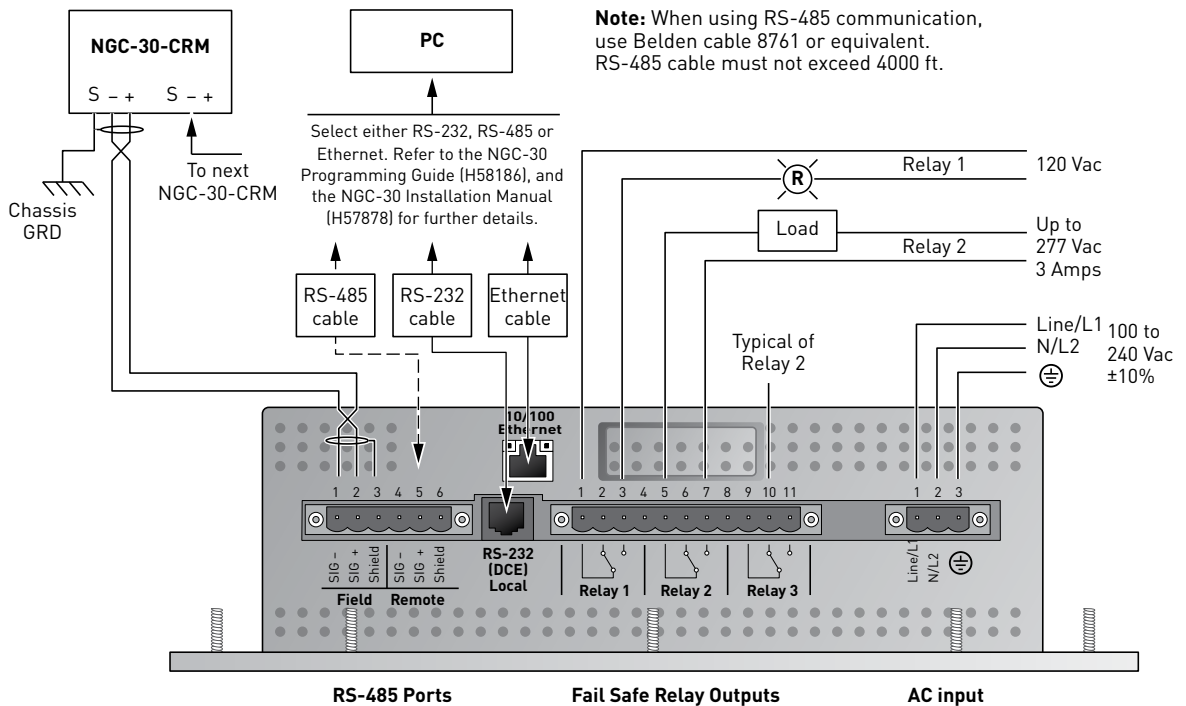

Note: Relays are shown in the energized position (without an alarm condition).

E. SERVICING

The NGC-UIT-ORD contains no user-serviceable parts. Contact your Pentair Industrial Heat Tracing Solutions representative for service and an authorization number if required.

F. CLEANING

The touch screen area of the NGC-UIT-ORD may be cleaned with a damp or dry cloth. Typical window cleaning agents may be applied to aid in the removal of dirt, dust and grease. **Do not use abrasive cleaners.**

G. CONFIGURATION SWITCHES

The configuration switches are found on the side of the NGC-UIT-ORD. Refer to the table below for settings.

Switch	Position		Comments
	On	Off	
TERM R-FIELD (Field Port Termination Select) Terminates local RS-485 network.	120 Ohm Termination Enabled (Factory Default)	Termination Disabled	For the local FIELD RS-485 network. If this NGC-UIT is the first or last RS-485 device in the network, it must be set to ENABLED/ON. If the NGC-UIT is NOT the first or last device, it must be set to DISABLED/OFF.
TERM R-REMOTE (Remote Port Termination Select) Terminates remote RS-485 network connected to PC and Raychem Supervisor software.	120 Ohm Termination Enabled	Termination Disabled (Factory Default)	For the REMOTE RS-485 network connected to a PC. If this NGC-UIT is the first or last RS-485 device in the remote network, it must be set to ENABLED/ON. If the NGC-UIT is NOT the first or last device, it must be set to DISABLED/OFF.
WDT (Watch Dog Timer)	WDT Enabled (Factory Default)	WDT Disabled	WDT should normally be enabled

H. RESET SWITCH

The Reset switch can be found on the side of the NGC-UIT-ORD. A pointed object is required to press the reset switch and restart the NGC-UIT software.

Side View



This Page Purposely Left Blank

Cut here

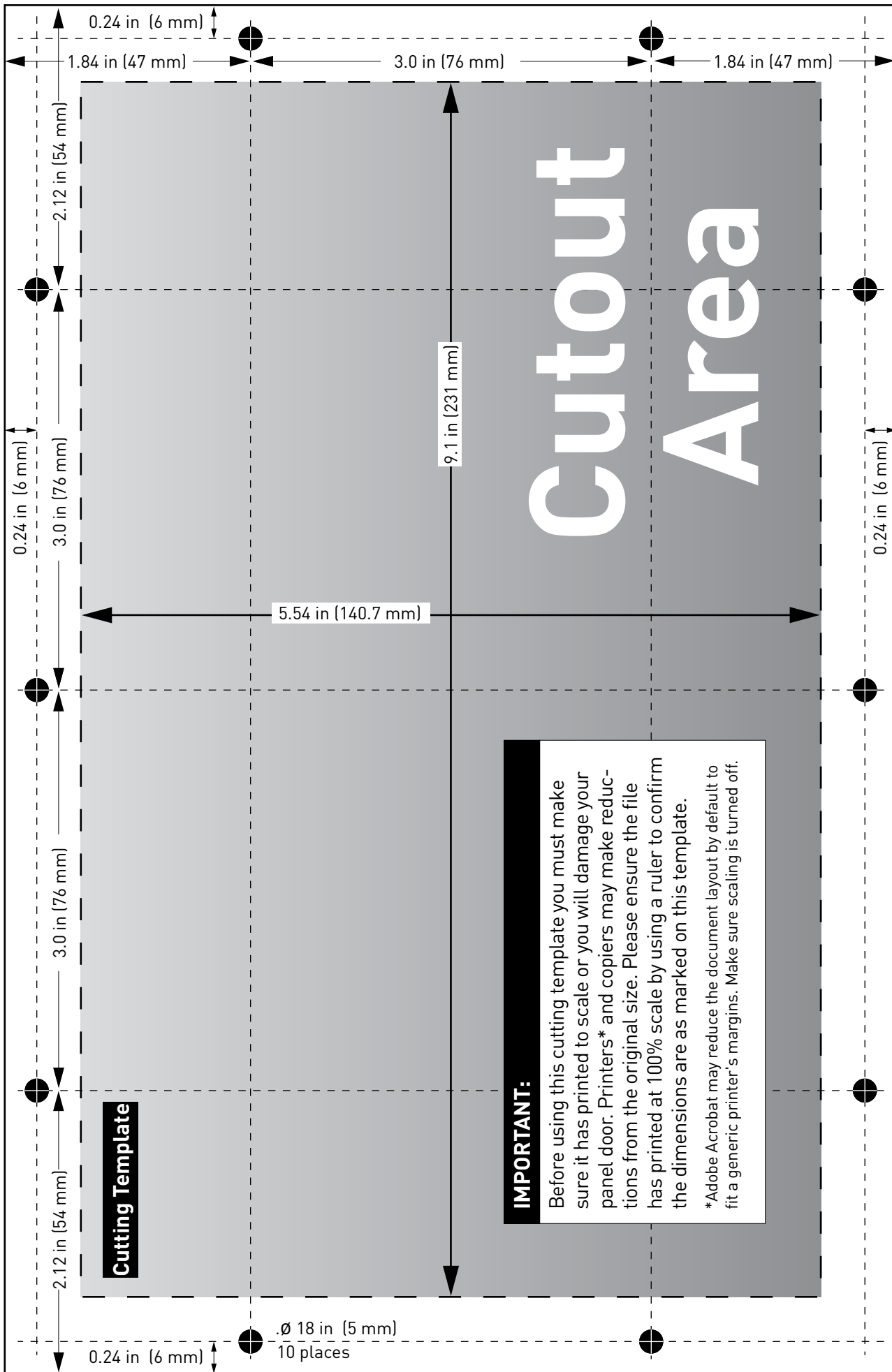

Cutting Template

IMPORTANT:
Before using this cutting template you must make sure it has printed to scale or you will damage your panel door. Printers* and copiers may make reductions from the original size. Please ensure the file has printed at 100% scale by using a ruler to confirm the dimensions are as marked on this template.
*Adobe Acrobat may reduce the document layout by default to fit a generic printer's margins. Make sure scaling is turned off.



WWW.PENTAIRTHERMAL.COM

NORTH AMERICA

Tel: +1.800.545.6258
Fax: +1.800.527.5703
Tel: +1.650.216.1526
Fax: +1.650.474.7711
thermal.info@pentair.com

EUROPE, MIDDLE EAST, AFRICA

Tel: +32.16.213.511
Fax: +32.16.213.603
thermal.info@pentair.com

ASIA PACIFIC

Tel: +86.21.2412.1688
Fax: +86.21.5426.2937
cn.thermal.info@pentair.com

LATIN AMERICA

Tel: +1.713.868.4800
Fax: +1.713.868.2333
thermal.info@pentair.com

Pentair and NGC are owned by Pentair or its global affiliates. All other trademarks are the property of their respective owners. Pentair reserves the right to change specifications without prior notice.

© 2013-2015 Pentair.